

PARTITION WALL SYSTEMS: ASSEMBLY INSTRUCTIONS

WIDE DOOR FRAME WITH HINGE INSERT PROFILE

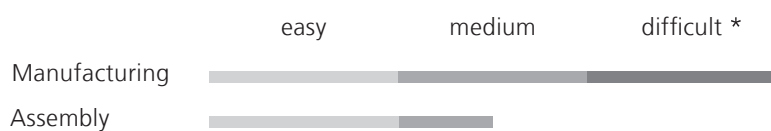

*Base for the degree of difficulty is a standard sliding door without slant.
This is to be classified as ,easy' in respect of production and installation.

raumplus

INDEX_

5th edition Bremen, January 2006

General information / Tools_page 3

Technical terms_page 4

Preparation_page 5

Assembly_pages 5-9

A_Wide door frame and glass ledge cut to size

B_Prepare drill holes

C_Screw on wide door frame

D_Attach gasket

E_Aufnahmeelement befestigen

F_Fasten pick-up element

G_Insert glass panel (top light)

Installation_page 10

Detail drawings_pages 11-19

_Overview fittings

_Example bill of door frame

_Determining the dimensions

_Mill and drill picture of the hinge view

_Drill picture for the solid glass door frame VXG 7990/120

_Section

_Top track middle strip removal

_Ground plate

_GENERAL INFORMATION / TOOLS

ASSEMBLY INSTRUCTIONS HINGE DOOR:

GENERAL INFORMATION

The hinge door from **raumplus** offers a wide range of variety and versatility. Tempered glass as well as wood are materials that can be used for the door leaf. For the assembly and installation of the hinge door please read the corresponding section.

These directions were created by people for people. We have made an effort to develop the instructions and pictures so that they are logical and easy to understand. If you should nevertheless find something to be unclear, please let us know so that we may revise that section.

Technical details are subject to change.

First of all, get a general idea about what you would like to design. Please check to see if you received all items by checking the delivery sheet. Please also pay attention to possible transport damages. In case of any damage please contact your supplier immediately. The single components are numbered on the detail drawing (page 13) as well as on the delivery sheet – please check.

ATTENTION: THE TOP LIGHT IS NOT DESCRIBED IN THE FOLLOWING DETAIL DRAWINGS / INSTRUCTIONS: ALL DETAIL DRAWINGS CORRESPOND TO A DOOR; OPENING SIDE DIN LEFT (RIGHT MIRROR-IMAGE TO LEFT)!!!

TOOLS:

Cross-tip screwdriver 2 mm (Phillips)
Allen key 4 mm and 5 mm
Drill; 6 mm; 3,5 mm; 2,5 mm drill bits
Superglue
Pencil
Rubber mallet
Metal saw

_TECHNICAL TERMS

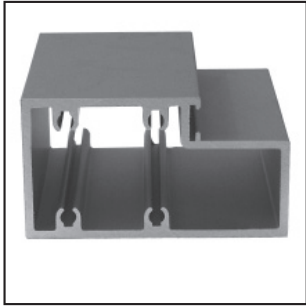

1_

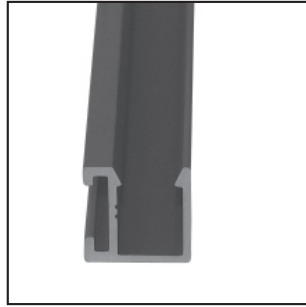

2_

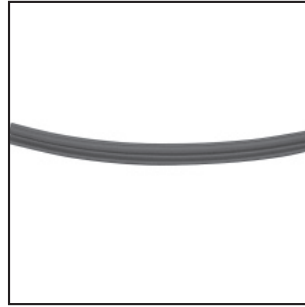

3_



4_



5_



6_



7_



8_



9_

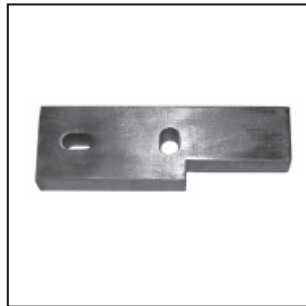

10_



11_



12_

1_Door frame wide (13.70.020)_support of the door leaf with door panel.

2_Glass ledge for door frame (13.73.020)_for fitting the top light.

3_Grey door frame gasket (10.07.039)_serves as a seal and to reduce noise.

4_Glass ledge screw (10.01.037)_for fitting the top light.

5_Pick up element (10.70.010)_to incorporate the hinge.

6_Hinge for all-glass doors VXG7990/120 (10.70.030)_for the support of the all-glass door. Important for the borings with glass doors.

7_Turning joint for light-weight wood doors (10.70.040)_support of the door leaf with door panel.

8_Turning joint for heavy-weight wood doors (10.70.042)_support of the door leaf with door panel.

9_Wing element for heavy-weight wood doors (10.70.052)_support of the door leaf with door panel.

10_Ground plate (10.70.020)_support of the door leaf with door panel on the floor.

11_Top track, 2 groove (14.05.0xx)_is screwed into the ceiling.

12_Hinge for heavy rabbeted doors VX 7939/120_Must be stated when ordering.

Drilling template wide (30.14.007)

Drilling template glass ledge (30.14.008)

_PREPARATION / ASSEMBLY

PREPARATION:

After having unpacked and checked the items you can start your assembly work. Particularly if you are assembling the hinge door alone, we recommend reading these instructions carefully before starting.

ASSEMBLY:

You will find detailed descriptions of the assembly steps in the following chapters. It is important that you follow these steps in correct order otherwise your hinge door could get damaged.

A_WIDE DOOR FRAME AND GLASS LEDGE CUT TO SIZE:

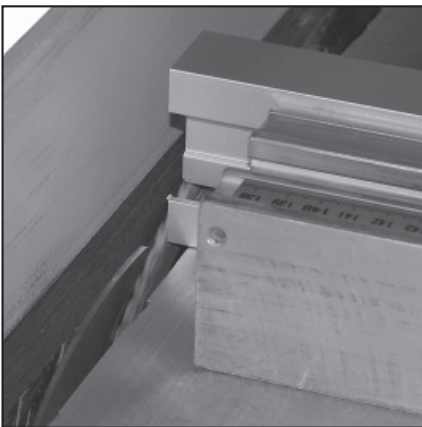

1_



2_

1_ Mark the areas to be cut (please take the dimensions from the detail drawing pages 16 and 17).

2_ Cut the door frame and glass ledge (use a mitre saw). Carefully cut slices in the door frame.

3_ Clean the cut areas thoroughly.

ASSEMBLY

B_PREPARE DRILL HOLES:



Mill in holes for the profiles, the lock and the hinges (without drilling template page 14) or with the help of the included drilling template (please take the exact dimensions from the detail drawings pages 14 to 16).

C_SCREW ON WIDE DOOR FRAME:

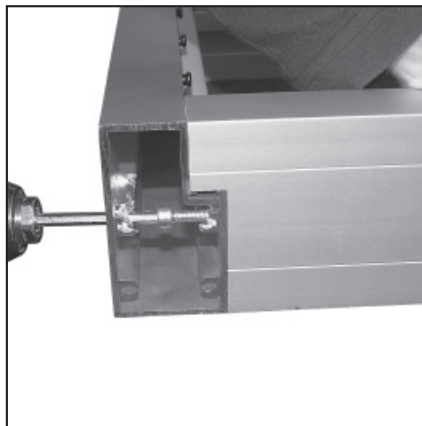
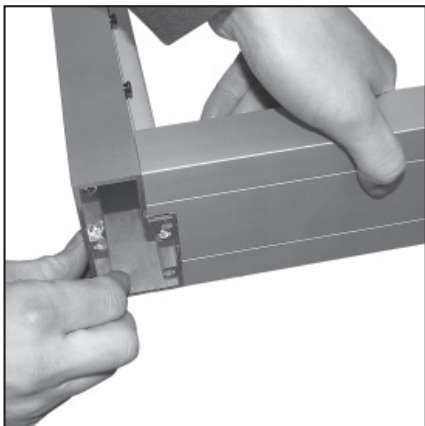

Screw the door jambs together to form the door frame. Screw the top flush and the middle according to the dimensions (please take the exact dimensions from the detail drawings page 17).

D_ATTACH GASKET:

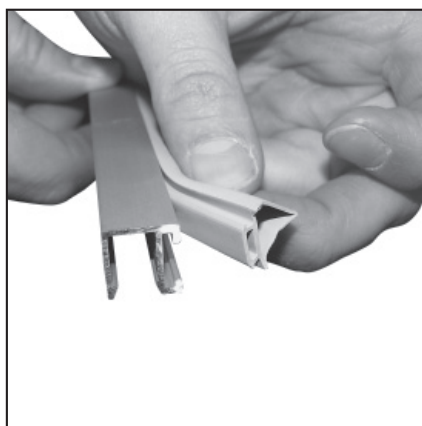
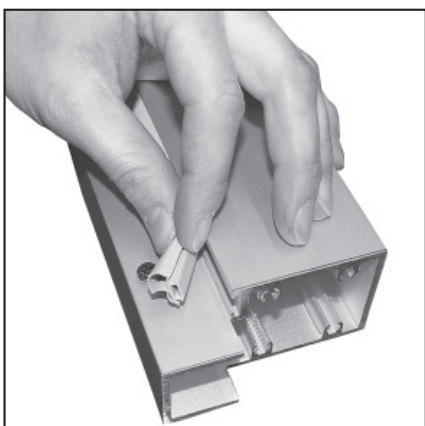

Attach the gasket in the door frame and the glass ledge into the appropriate position.

ASSEMBLY

E_FASTEN PICK-UP ELEMENT:

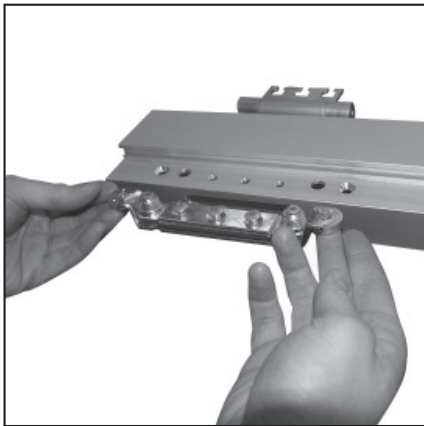

1_

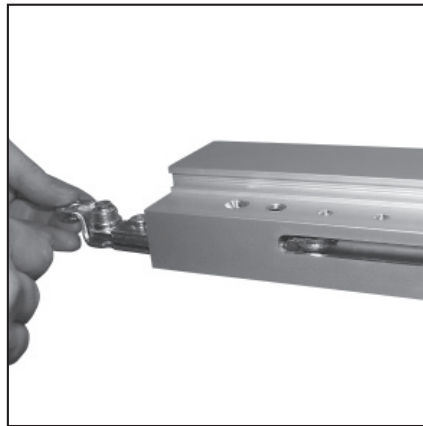

2_



3_

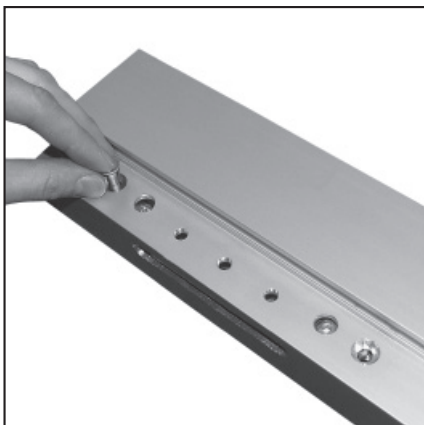

4_

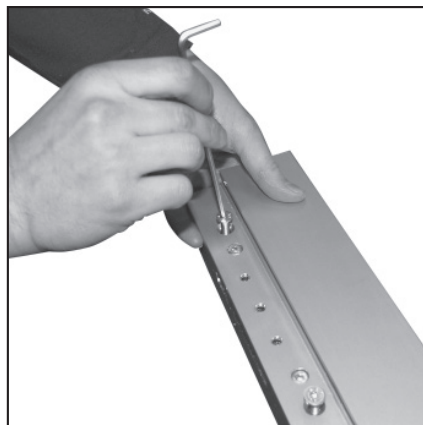

5_



6_

1_ Push the pick-up element into the door frame and position it where the pre-drilled holes are. When you attach various pick-up elements, you have to push them with a long narrow object into the proper position (pictures 1_ to 3_).

2_ Lift the pick-up element and pull it to the front. Then tighten it using the designated screws (pictures 4_ to 6_).

_ASSEMBLY

F_MOUNT HINGES:

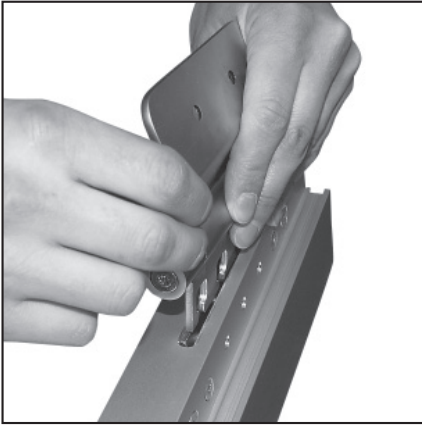

1_

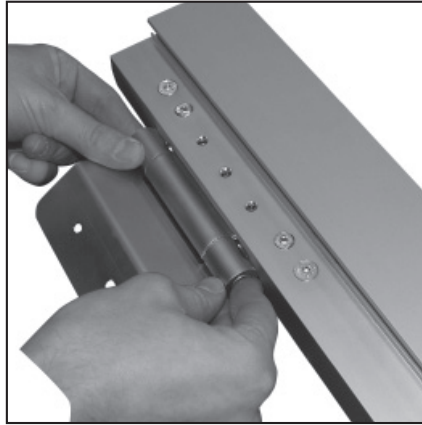

2_

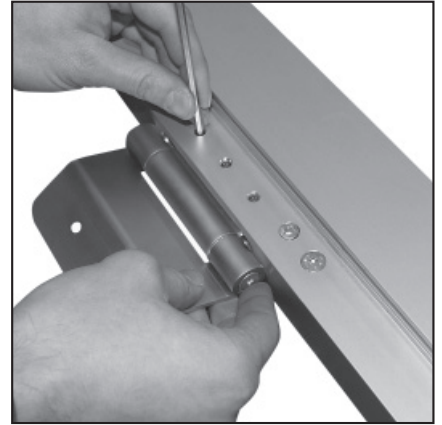

3_

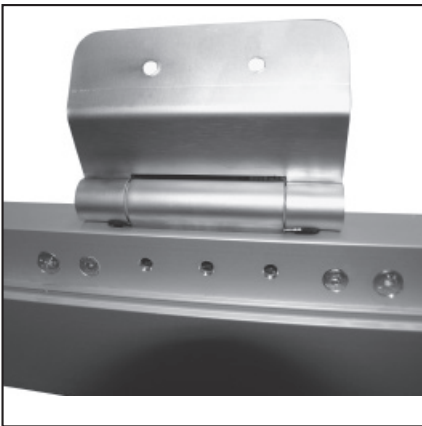

4_

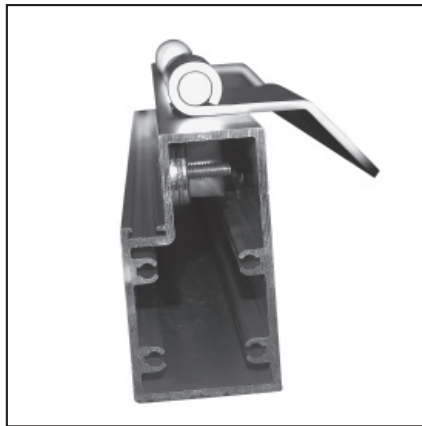

5_

Special case wood door:

The wing element and the turning joint are used with a wood door. The turning joint is pushed into the pick-up element and the wing element is attached to the wood door.

1_ Push the pick-up element apart and push the hinge inside (pictures 1_ to 2_).

2_ Tighten the three screws in the middle (picture 3_). After the assembly of the door the door frame can be aligned into the appropriate height.

_ASSEMBLY

G_INSERT GLASS PANE (TOP LIGHT):

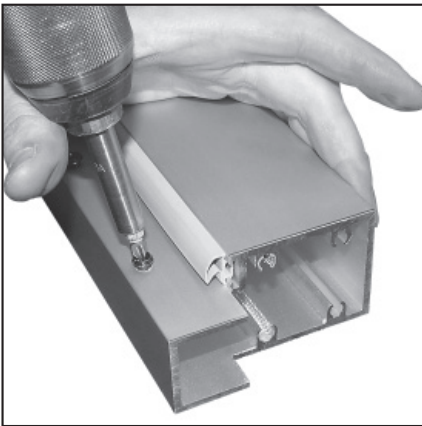

1_

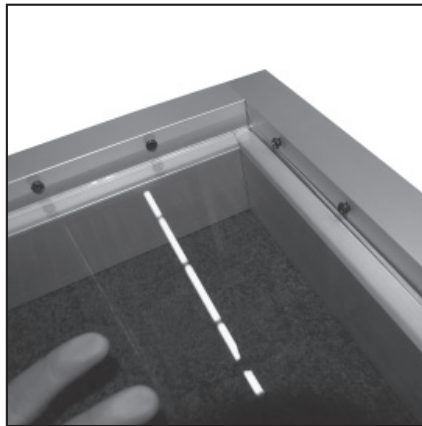

2_



3_

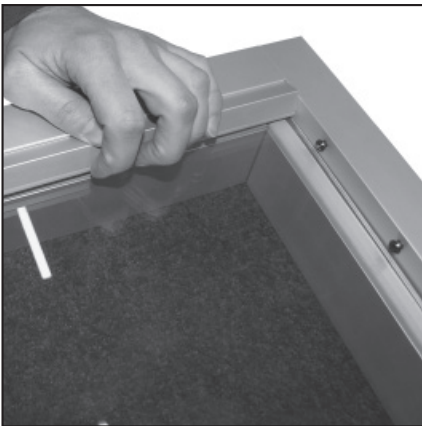

4_

Tighten the screws for the glass ledge profile into the equally spaced pre-drilled holes (picture 1_). Use the drilling template to do this.

Insert the glass pane (picture 2_) and clip the glass ledges to the glass ledge profile screws (pictures 3_ and 4_).

_INSTALLATION

A_INSTALLING DOOR FRAME:



1_

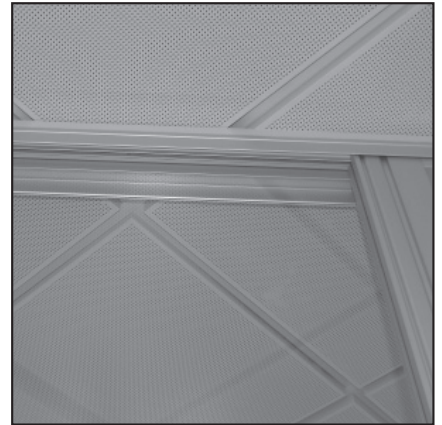

2_

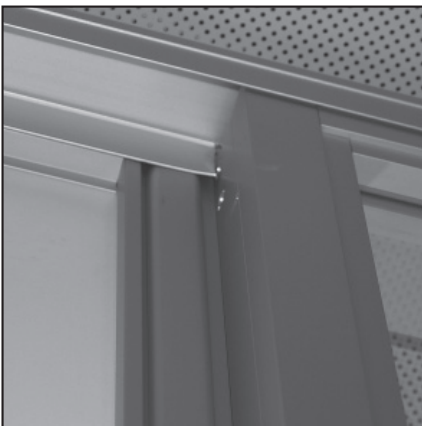

3_



4_



5_

1_ First move the middle strip out of the top track, in the width of the door frame.

2_ Attach the top tracks to the appropriate position on the ceiling.

3_ Now assemble from left to right, e.g. set element-> door frame -> set element (see picture 1_).

4_ Mark the position of the ground plate and mount them.

5_ Set the door frame into the top track first and then into the ground plate (see pictures 2_ to 4_).

_DETAIL DRAWING

OVERVIEW FITTINGS

Overview of fittings

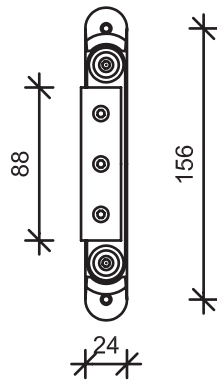

Pick-up element VX 7621 3D

Wood doors,
heavy design

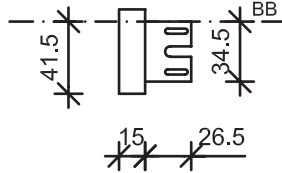

Turning joint
Simonswerk V 8000 WF

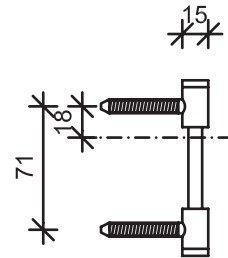

for use with wing element
Simonswerk V 8000 WF

Wood doors,
heavy doors

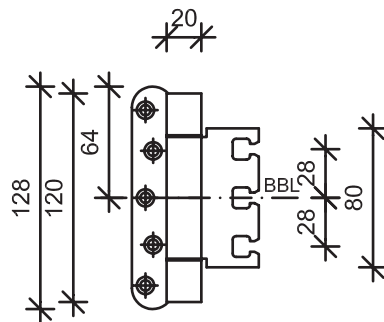

Variant
hinge for rabbeted doors
Simonswerk VX 7939/120

Glass doors

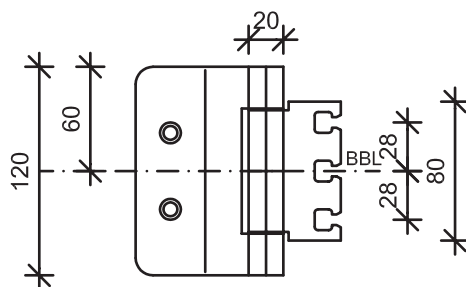

Variant
hinge for all-glass doors
Simonswerk VXG 7990/120
for glass strenghts 8 and 10

_DETAILZEICHNUNG

EXAMPLE ARITHMETIC OF DOOR FRAME

Example arithmetic of door frame

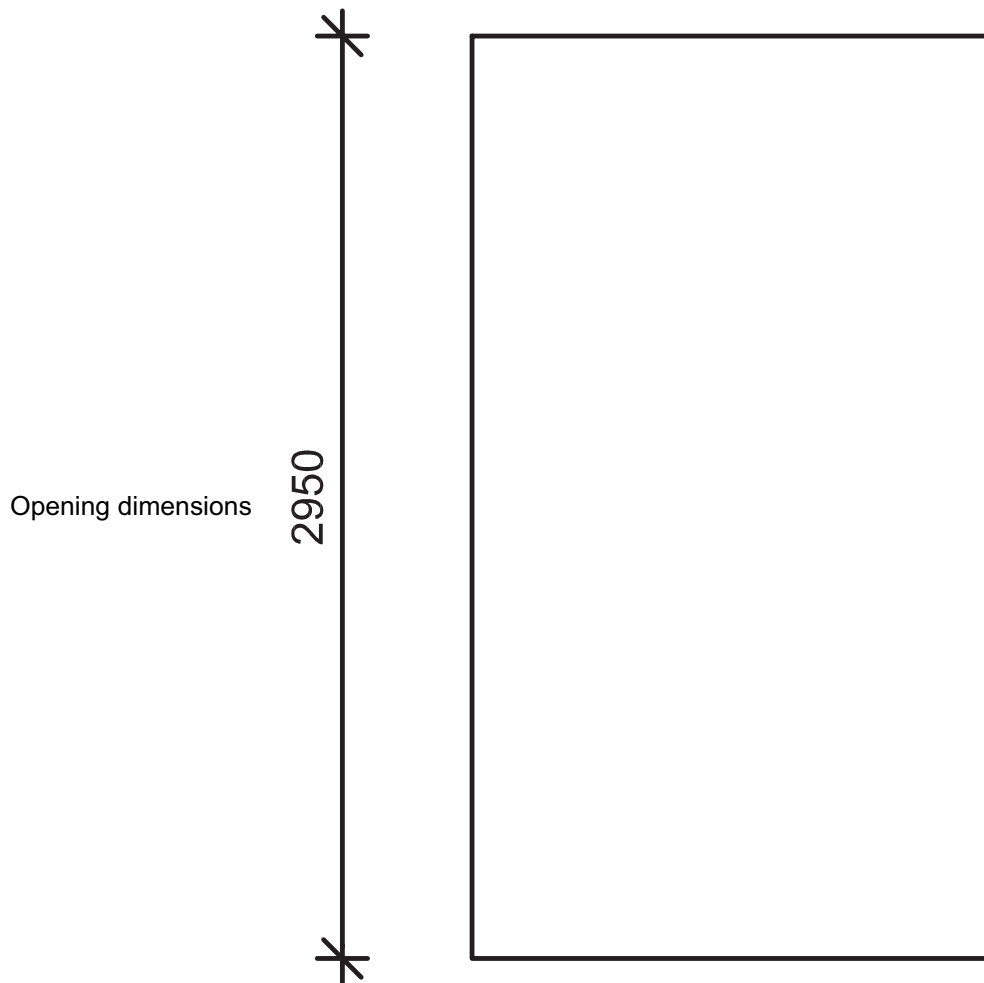

height and width of door to be installed = 1985 x 985

Outside frame dimension = 985 mm + 51 mm = 1036 mm
Length of horizontal Profiles = 1036 mm - 70 mm = 966 mm
Length of vertical profile = 2950 mm - 20 mm = 2930 mm

_DETAILZEICHNUNG

DETERMINING THE DIMENSIONS

Determining the dimensions

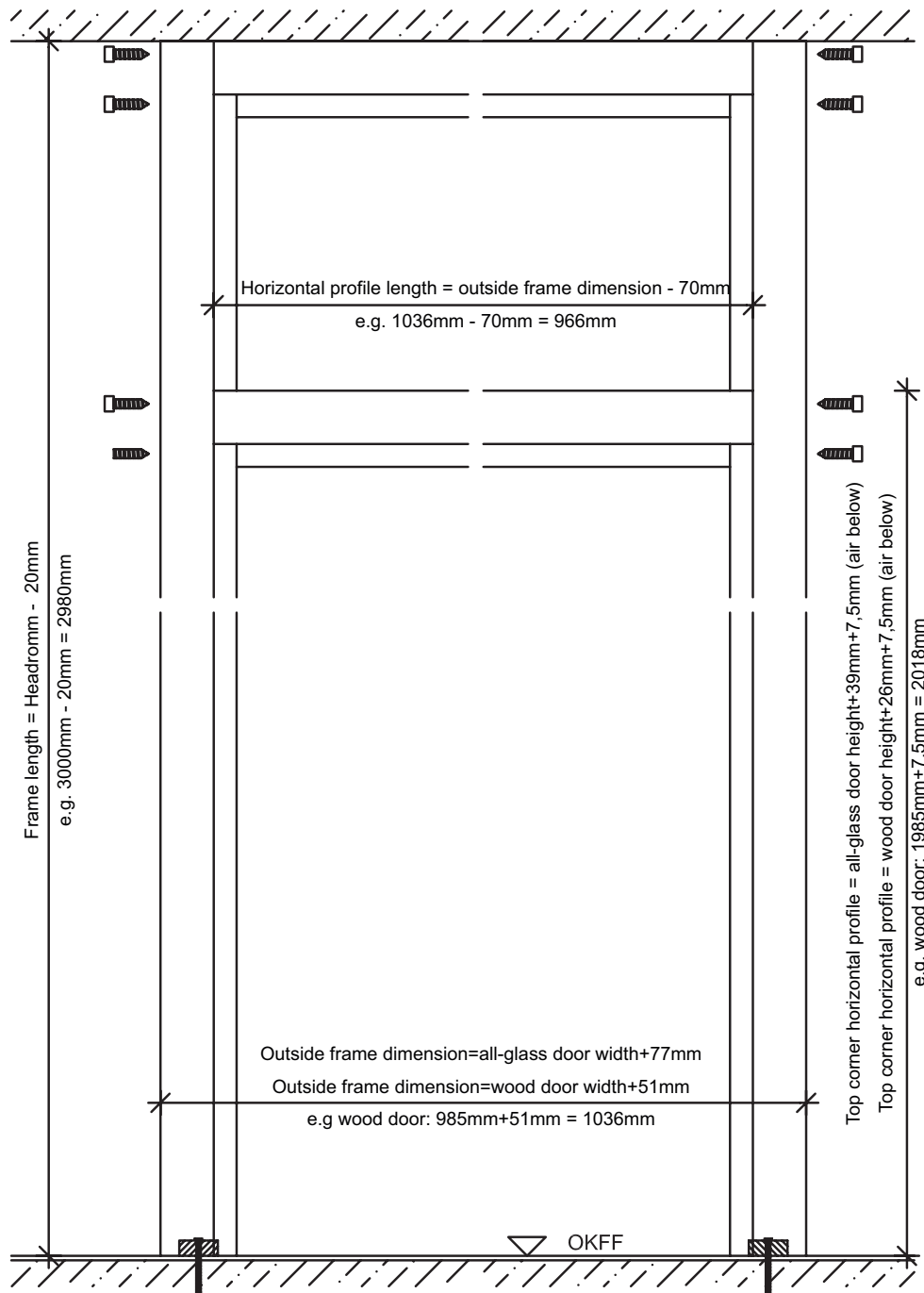

1. Cut profiles to length
2. Notch the frame rabbet on the horizontal profile

_DETAILZEICHNUNG

SIDE VIEW

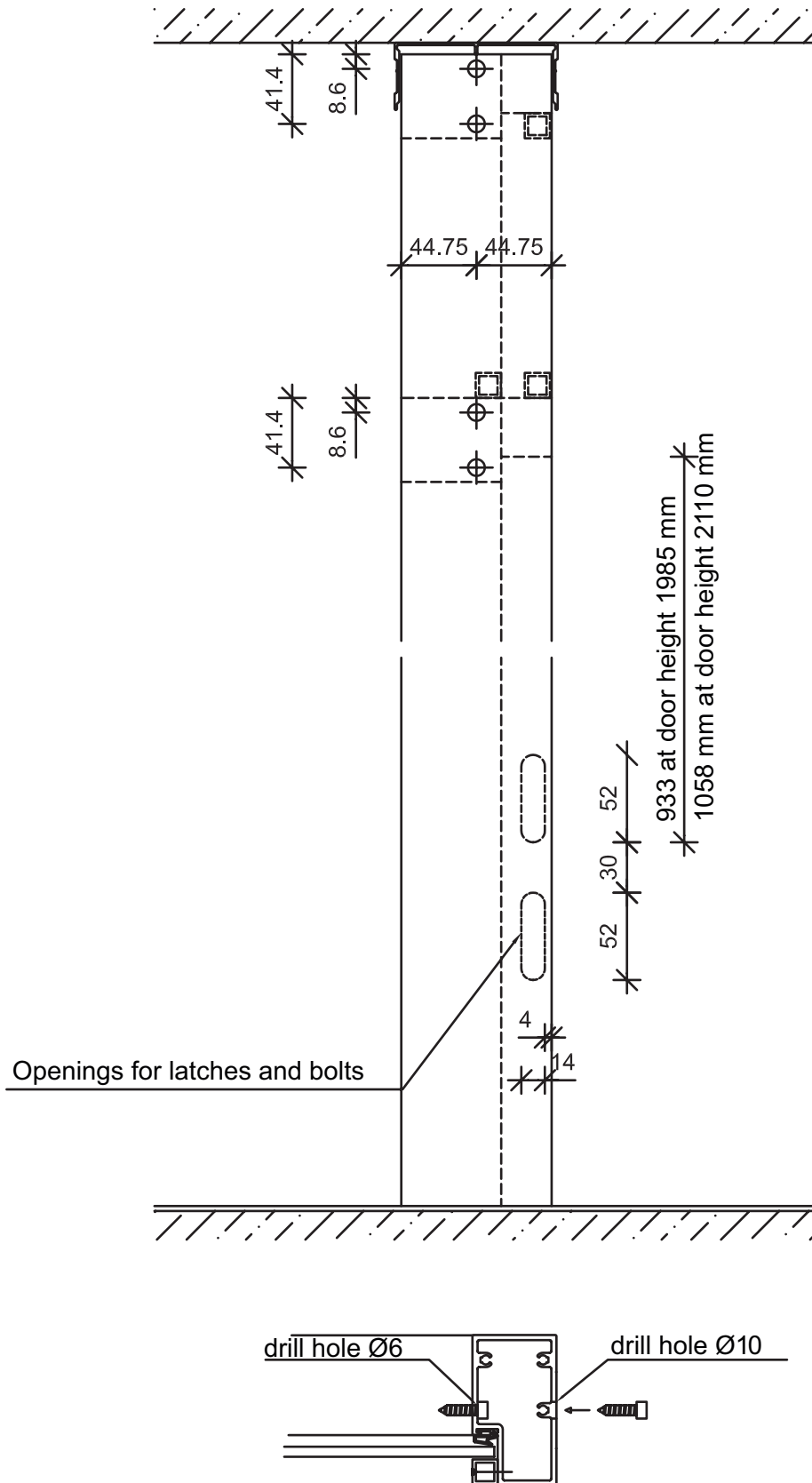

_DETAILZEICHNUNG

MILL AND DRILL PICTURE OF THE HINGE

Mill and drill picture of the hinge

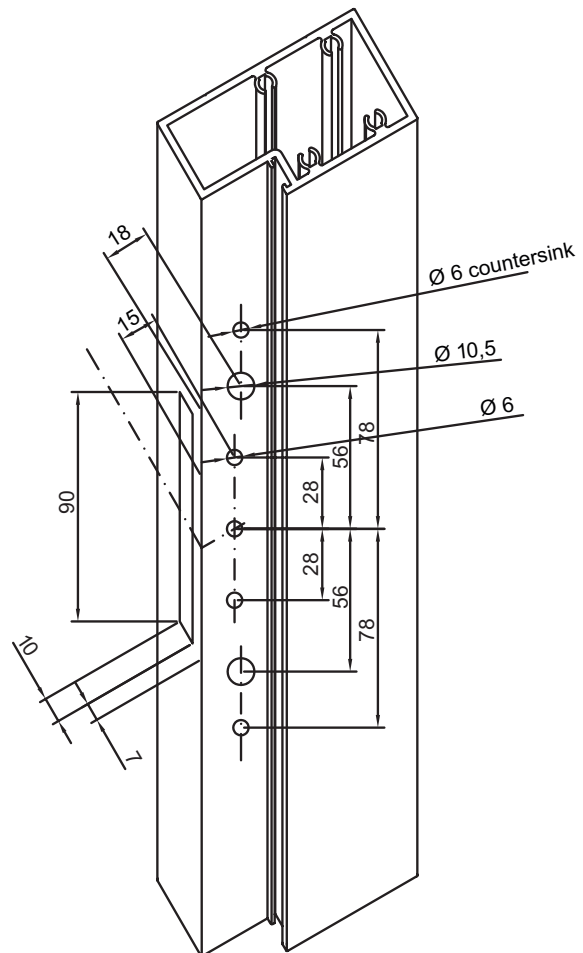
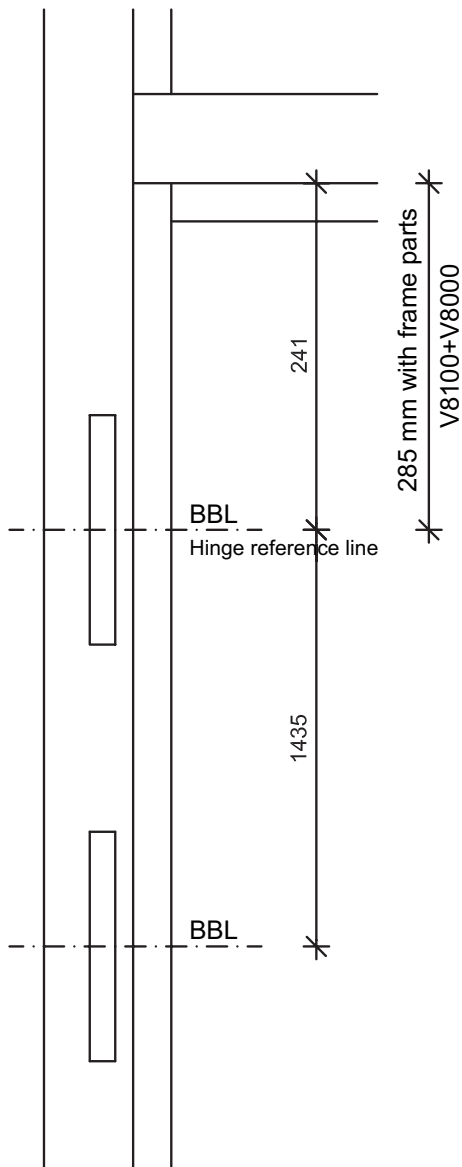

5. Carry out borings and millings
for pick-up element.

_DETAILZEICHNUNG

SECTION

Section

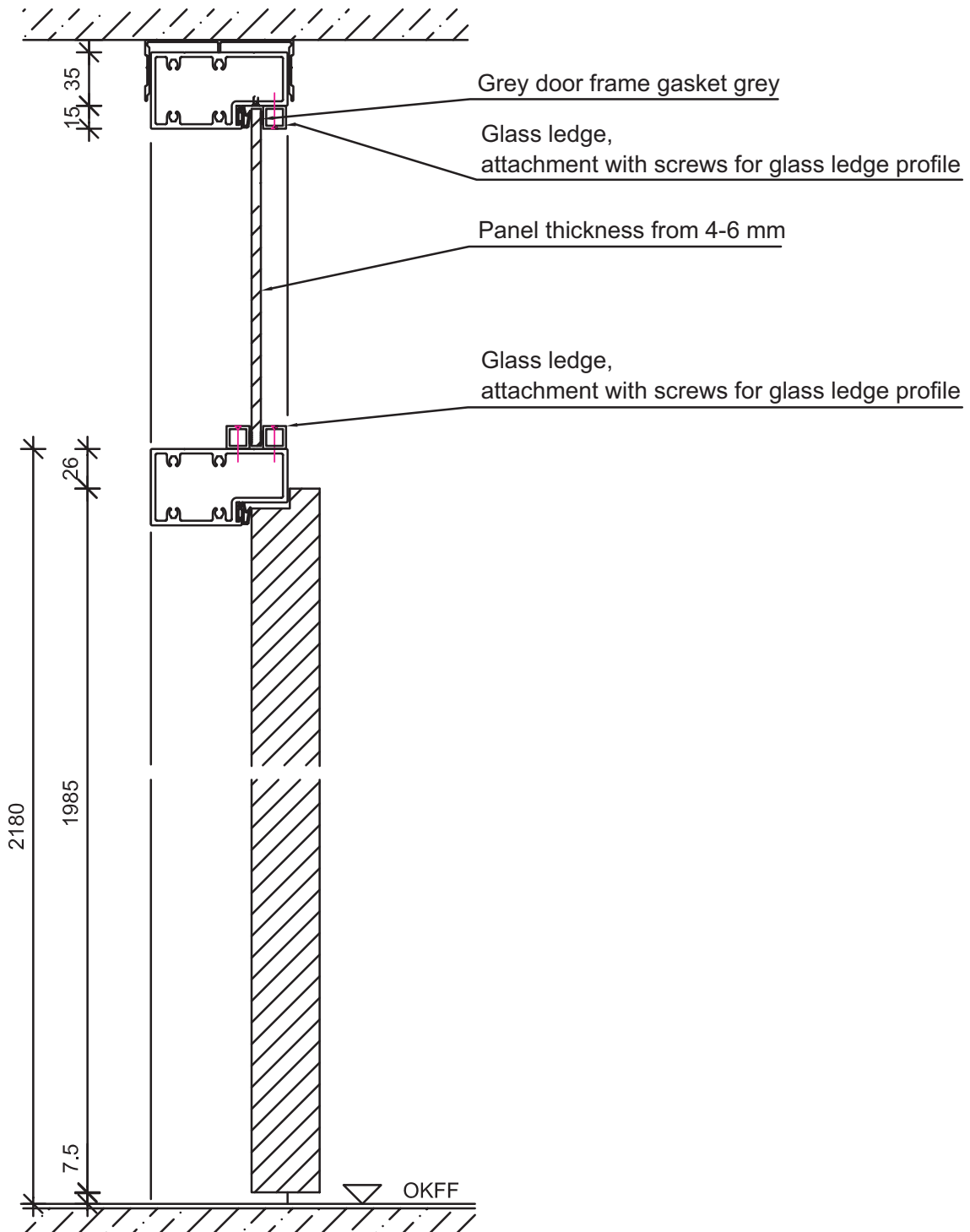

_DETAILZEICHNUNG

TOP TRACK MIDDLE STRIP REMOVAL

Top track middle strip removal

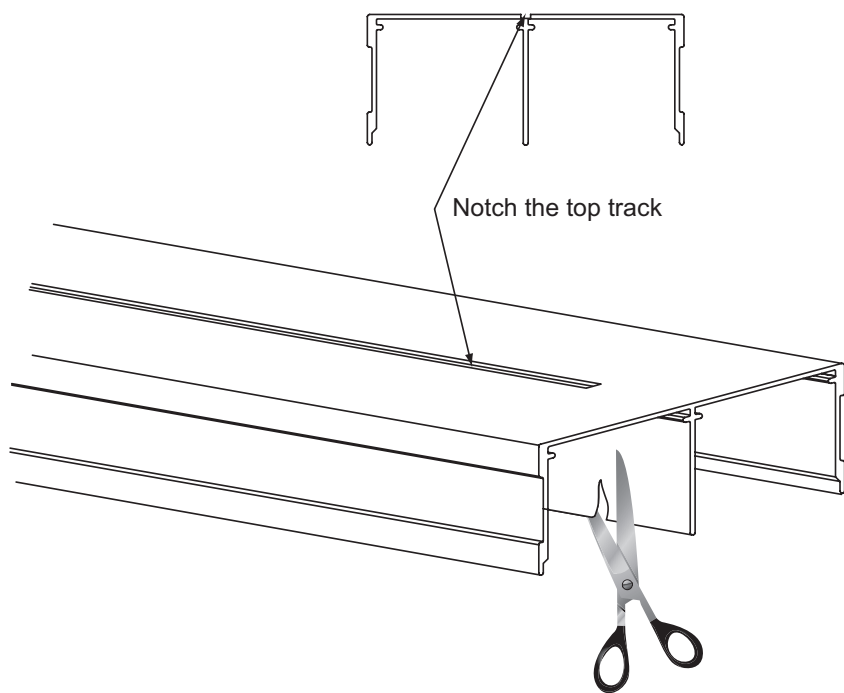
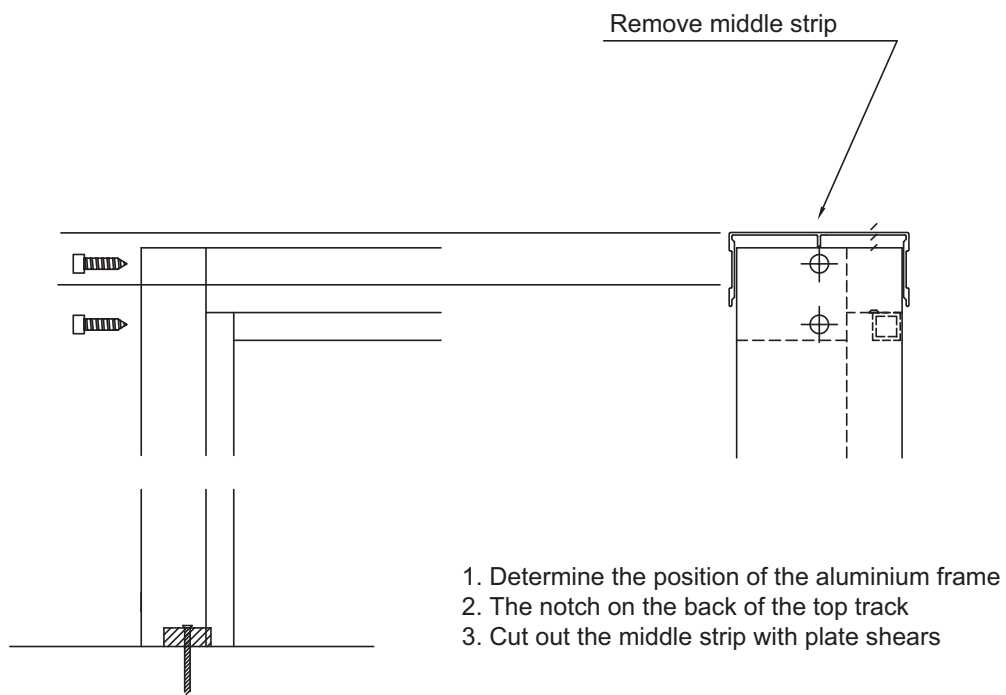

Cut out the middle strip with plate shears

_DETAILZEICHNUNG

GROUNDPLATE

Groundplate,
against sideways displacement
to be screwed in on site by customer

