

# SLIDING DOOR SYSTEMS: ASSEMBLY INSTRUCTIONS

## SOLID DOOR / FRAMELESS WOOD DOOR (42 MM SYSTEM)

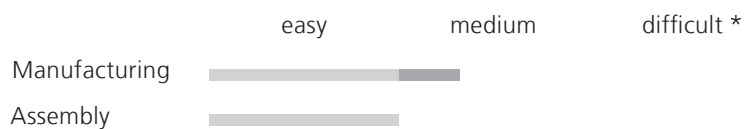

\*Base for the degree of difficulty is a standard sliding door without slant.  
This is to be classified as ,easy' in respect of production and installation.

**raumplus**

# INDEX\_

5<sup>th</sup> edition Bremen, January 2006

**General information / tools**\_page 3

**Technical terms**\_page 4

**Preparation / Assembly**\_pages 4-7

A\_Cut and drill bottom rail

B\_Cut door leaf to measure and drill

C\_Mount top rollers

D\_Mount bottom rail

E\_Mount bottom rollers

**Detail drawings**\_page 8-11

# \_GENERAL INFORMATION / TOOLS

## ASSEMBLY INSTRUCTIONS SLIDING DOOR SYSTEM:

### GENERAL INFORMATION

**raumplus** sliding door systems offer a wide range of variation possibilities. There are systems with and without bottom tracks, a great number of panel variations, doors for sloped ceilings and corner solutions or doors for special application purposes (lockable, application as room divider etc.). For installation of the sliding doors, assembled according to these assembly instructions, please use the installation instructions.

These directions were created by people for people. We have made an effort to develop the instructions and pictures so that they are logical and easy to understand. If you should nevertheless find something to be unclear, please let us know so that we may revise that section. **Technical details are subject to change.**

First of all, get a general idea about what you would like to assemble.

#### **Are you installing ready-made sliding doors?**

These instructions are the instructions for a solid door / frameless door. Please read the installation instructions for sliding doors.

Please check to see if you received all items by checking the delivery sheet. Please also look out for possible transport damages. In case of any damage please contact your supplier immediately. The single components are numbered on the detail drawing as well as on the delivery sheet – please check.

**REMARKS:** Before starting please read our measurement instructions in order to find the correct measures. Handles do not belong to the ordinary delivery.

### TOOLS:

Cross tip screwdriver (Phillips)

Allen wrench

Drill

# \_TECHNICAL TERMS / PREPARATION

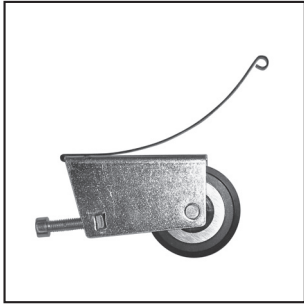

1\_

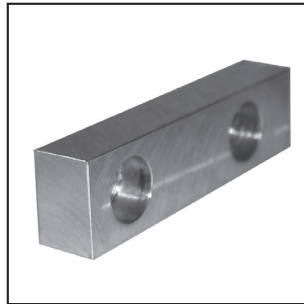

2\_

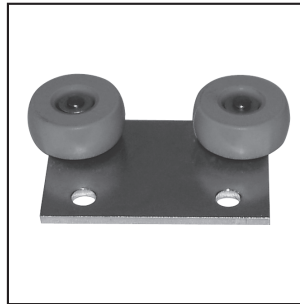

3\_



4\_

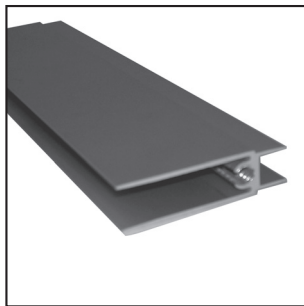

5\_

**1\_Bottom roller with antijump spring (10.01.120, screw 30 mm)**\_bottom roller to be inserted into the bottom rail.

**2\_Bottom roller connector for solid door / frameless all-wood door (10.09.020)**\_holds the rollers within the bottom rail.

**3\_Top roller for solid door (10.01.019)**\_is to be affixed directly to the panel.

**4\_Top roller for solid door (10.01.029)**\_narrow design.

**5\_Bottom rail (15.04.0xx)**\_for the bottom rollers.

## PREPARATION:

Please check to see if you received all items by checking the delivery sheet. Please look for possible transport damages. In case of any damage please contact your supplier immediately. The single components are numbered on the detail drawing as well as on the delivery sheet – please check.

## ASSEMBLY:

You will find detailed descriptions of the assembly steps in the following chapters. It is important that you follow these steps in correct order otherwise your sliding door system could get damaged. It is important that your work is accurate.

# \_ASSEMBLY

## A\_CUT BOTTOM RAIL AND DRILL:

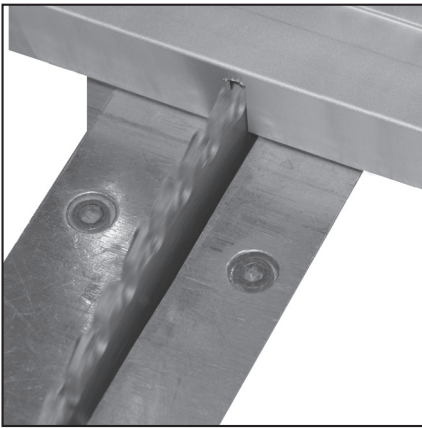

- 1\_After you have determined the width, mark the cutting points.
- 2\_Cut bottom rail to length (width of the all-wood door -20 = length of the bottom rail) and clean the cut surfaces carefully.
- 3\_Drill holes into the groove in the bottom rail (see detail drawing on page 11).

## B\_CUT DOOR LEAF TO MEASURE AND DRILL:

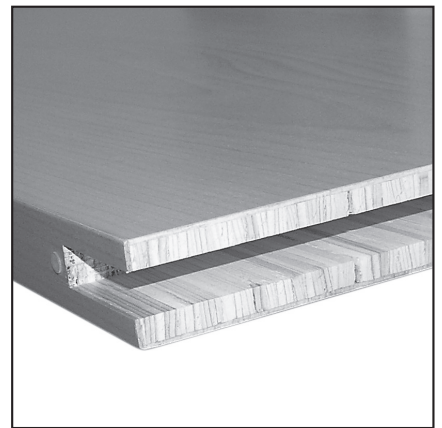
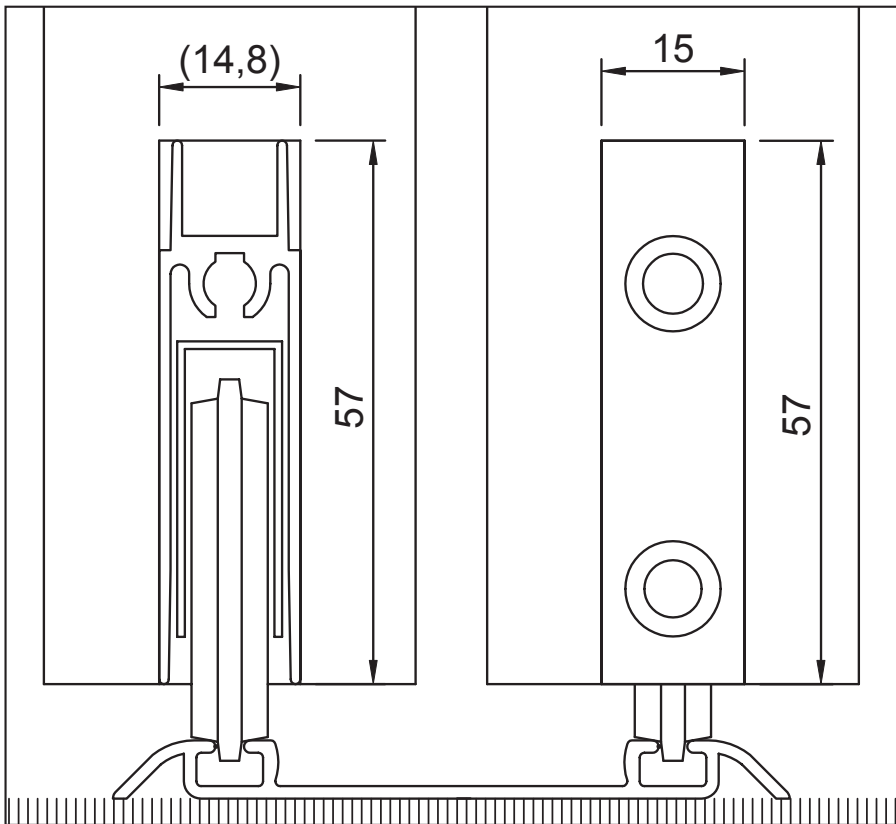

Cut door leaf to desired measure and mill a groove into the bottom edge (see detail drawing on page 11).

# \_ASSEMBLY

## C\_MOUNT TOP ROLLERS:

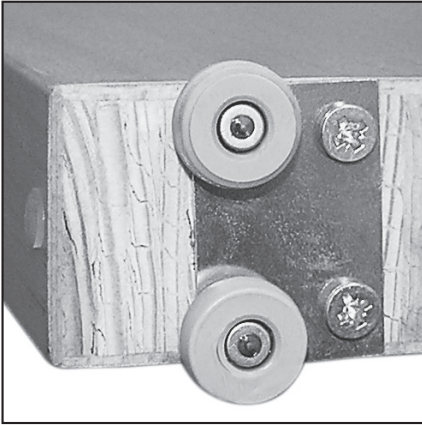

The top rollers are screwed directly onto the wood door.

## D\_MOUNT BOTTOM RAIL:



1\_



2\_

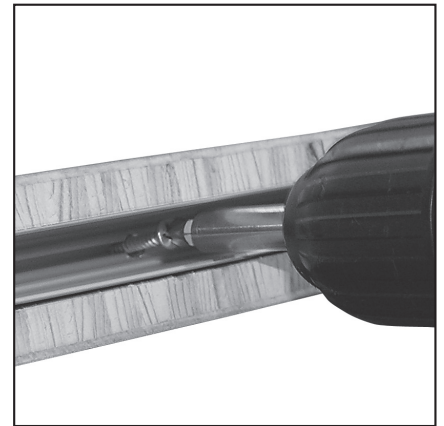

3\_

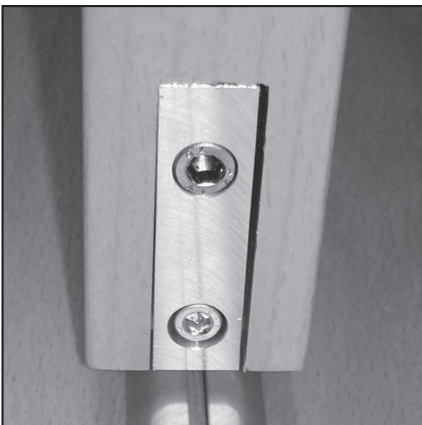

4\_

The bottom rail is to be inserted in the milled groove and to be screwed with the door.

# \_ASSEMBLY

## E\_MOUNT BOTTOM ROLLERS::

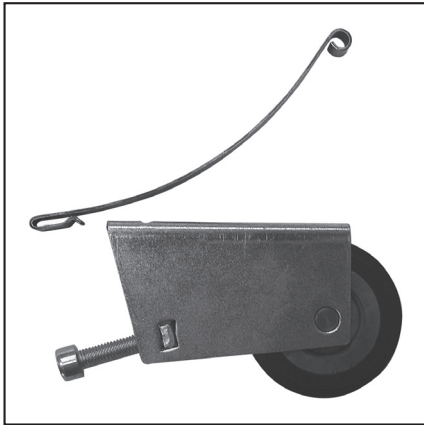

1\_

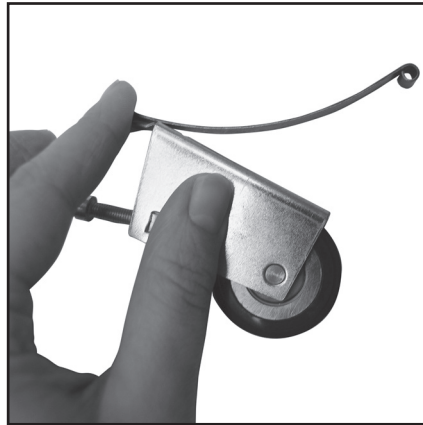

2\_



3\_

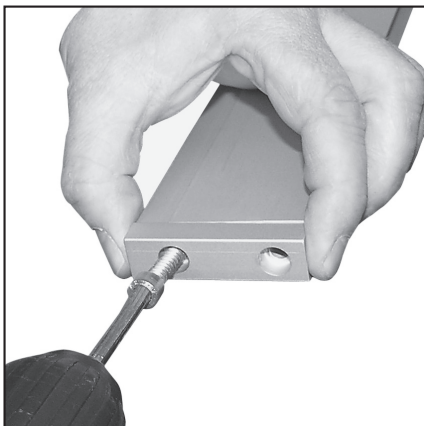

4\_



5\_

**ATTENTION:** Before mounting the bottom roller you have to affix the antijump spring at the roller (pictures 1\_ and 2\_).

1\_ Insert the bottom roller into the bottom rail (picture 3\_):

2\_ Screw the roller and the bottom roller connector together (pictures 4\_ and 5\_).

# \_DETAIL DRAWING

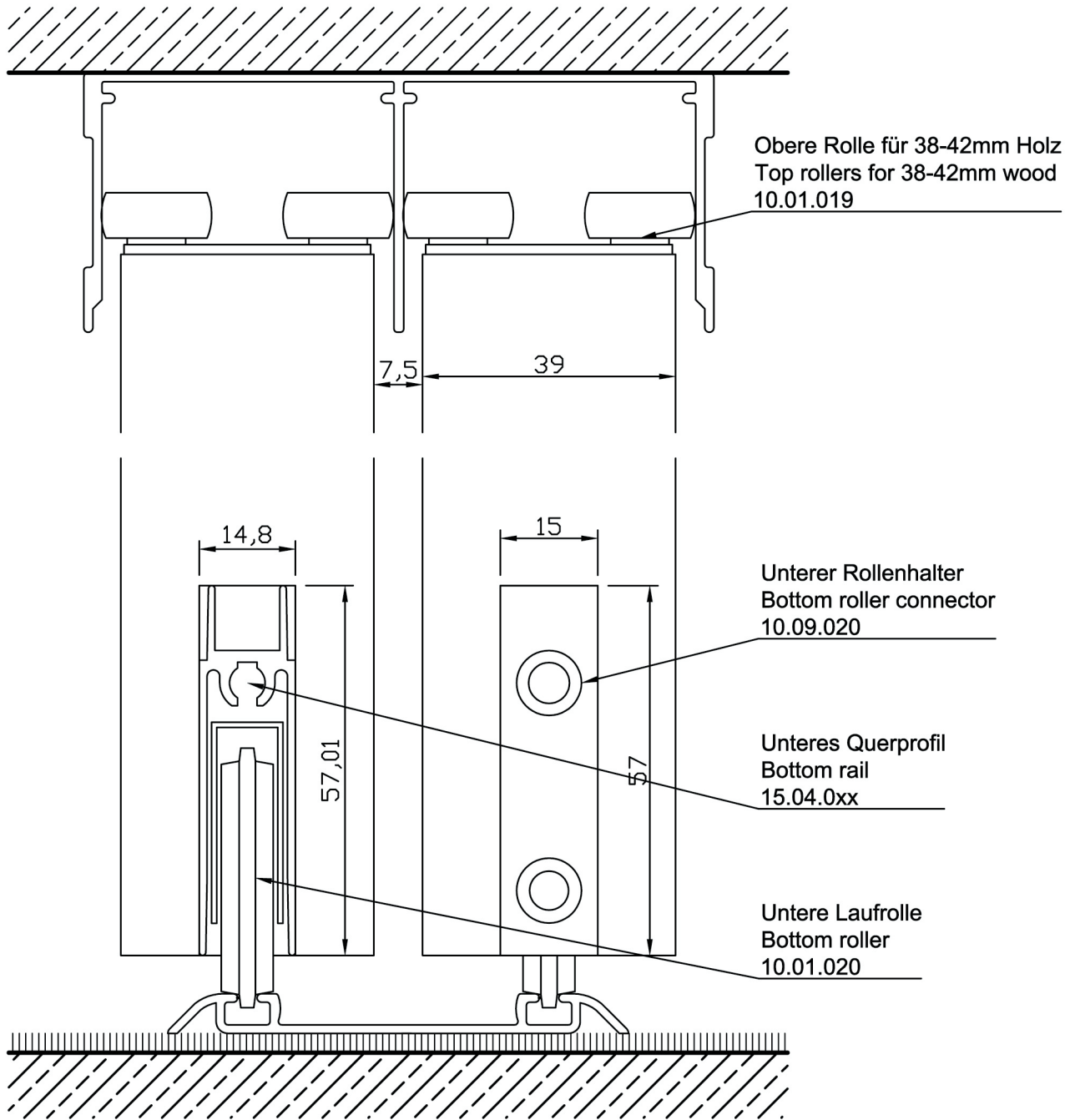

# \_DETAIL DRAWING

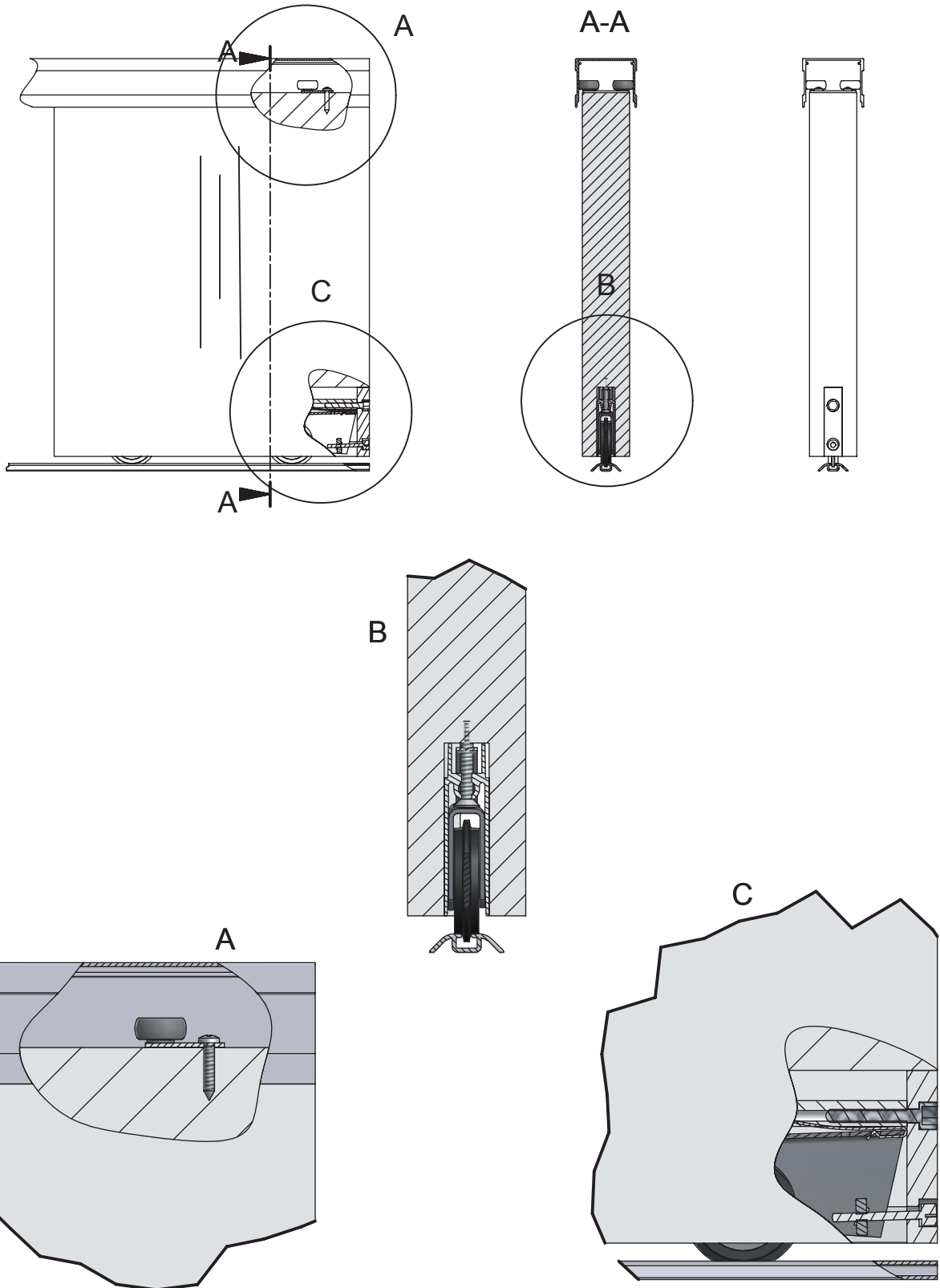

# \_DETAIL DRAWING

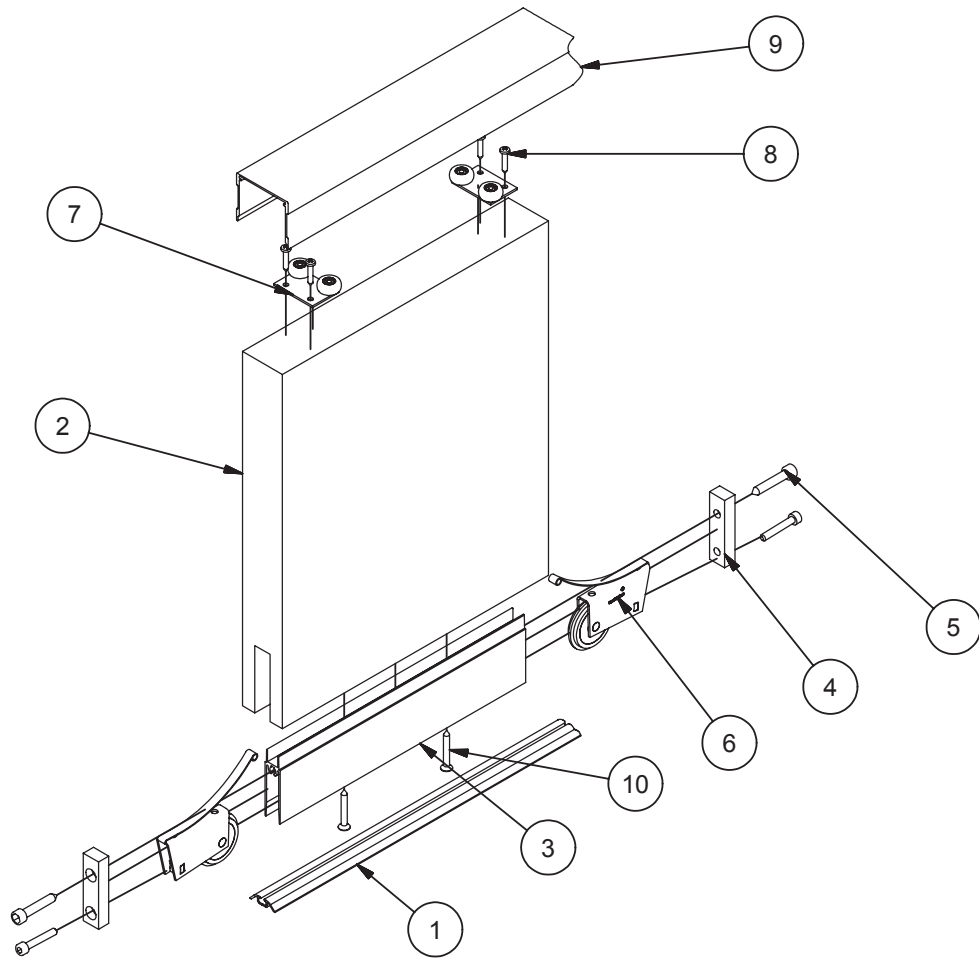

Item list

OBJECT	QUANTITY	UNIT NUMBER	DESCRIPTION
1	1	14.56.0xx	Bottom track
2	1	All-wood door	Derived fimber product
3	1	15.04.0xx	Bottom rail
4	2	10.09.020	Bottom roller connector
5	2	10.07.012	Frame screw 32 mm
6	2	10.01.120	Bottom roller
7	2	10.01.019	Top roller all wood door
8	4	fastening screw	Not included
9	1	14.15.0xx	Top track-42-1L
10	2	fastening screw	Not included

# \_DETAIL DRAWING

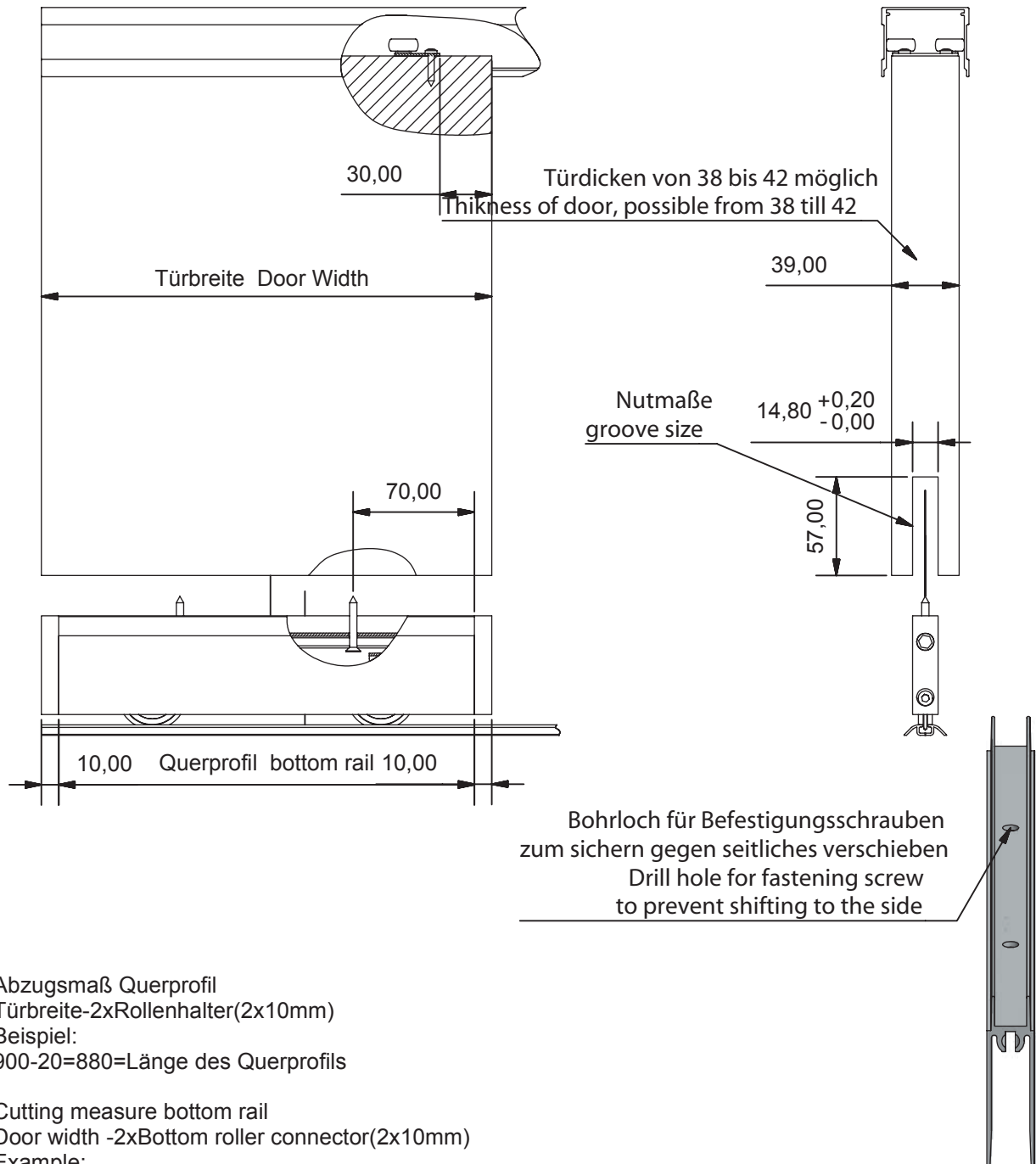

Abzugsmaß Querprofil  
Türbreite-2xRollenhalter(2x10mm)  
Beispiel:  
900-20=880=Länge des Querprofils

Cutting measure bottom rail  
Door width -2xBottom roller connector(2x10mm)  
Example:  
900-20=880=Length of the bottom rail